

ALTERNATORS 145 STK

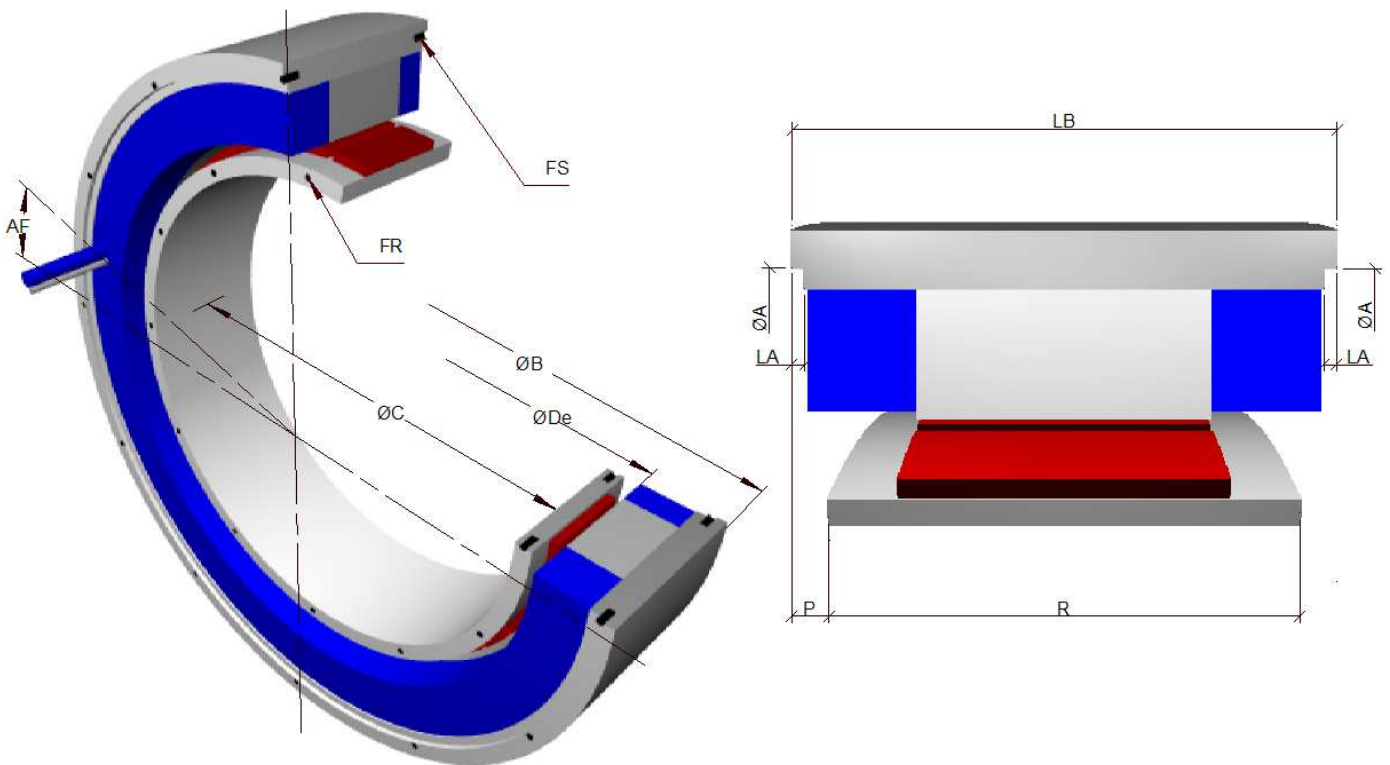

		145STK1M	145STK2M	145STK3M	145STK4M	145STK5M	145STK6M	145STK7M	145STK8M
Housing internal centering diameter	A H8	130	130	130	130	130	130	130	130
Angle wire output / tapped holes	AF	22°30'	22°30'	22°30'	22°30'	22°30'	22°30'	22°30'	22°30'
Housing external centering diameter	B Ø	145	145	145	145	145	145	145	145
Rotoric internal centering diameter	C H7	56	56	56	56	56	56	56	56
Housing internal diameter	De	78.5	78.5	78.5	78.5	78.5	78.5	78.5	78.5
Rotoric fixation holes	FR	8xM5 sur Ø63	8xM5 sur Ø63	8xM5 sur Ø63	8xM5 sur Ø63	8xM5 sur Ø63	8xM5 sur Ø63	8xM5 sur Ø63	8xM5 sur Ø63
Housing fixation holes	FS	8xM5 sur Ø136	8xM5 sur Ø136	8xM5 sur Ø136	8xM5 sur Ø136	8xM5 sur Ø136	8xM5 sur Ø136	8xM5 sur Ø136	8xM5 sur Ø136
Depth of housing internal centering diameter	LA	2	2	2	2	2	2	2	2
Housing length	LB ±0.15	92	119	146	173	200	227	254	281
Alignment rotor / housing	P ± 0.1	20.5	20.5	20.5	20.5	20.5	20.5	20.5	20.5
Maximum rotoric contact diameter	Pmax	75	75	75	75	75	75	75	75
Rotor length	R +0.15	59	86	113	140	167	194	221	248
Number of poles (number of pairs of poles)		12 (6)	12 (6)	12 (6)	12 (6)	12 (6)	12 (6)	12 (6)	12 (6)

INTEGRATION :

- ✓ The cables are made of PU, class 6, foreseen for cable-bearing chains, 2 mt standard length, copper square section according rated current.
- ✓ Rotor / housing alignment (P) has to be executed within +/- 0.1 mm. Optionally, we can supply a mounting tool for achieving that alignment in case of assembly without possibility of accurate alignment.
- ✓ Thermal device cable consists of a shielded pair 2x2x0.25mm² section, 7mm external diameter.
- ✓ (De) represents:
 - 1- The maximum diameter passing inside the housing.
 - 2- The maximum diameter necessary for rotor assembly.
- ✓ (Pmax) diameter for pieces in contact with the rotor must never be exceeded.
- ✓ Tapped holes on each side of rotor and housing are angularly aligned.
- ✓ Cable positioning (AF) is theoretical. Leave a free room with a +/- 10 arc degrees tolerance around that position, on a 50 mm height from the housing side, for avoiding to force the cables at the alternator output.
- ✓ When designing the assembly, take care to insure a perfect contact between housing and user's bore for avoiding thermal problems.
- ✓ For housing mounting, use either external centering diameter (B) or internal centering diameters (A).
- ✓ For execution tolerances (perpendicularity, concentricity...), please consult us.

A full integration handbook can be supplied to our customers upon request
 For further information or specific request about our alternators, feel free to contact us.