

# ALTERNATORS 400 STK

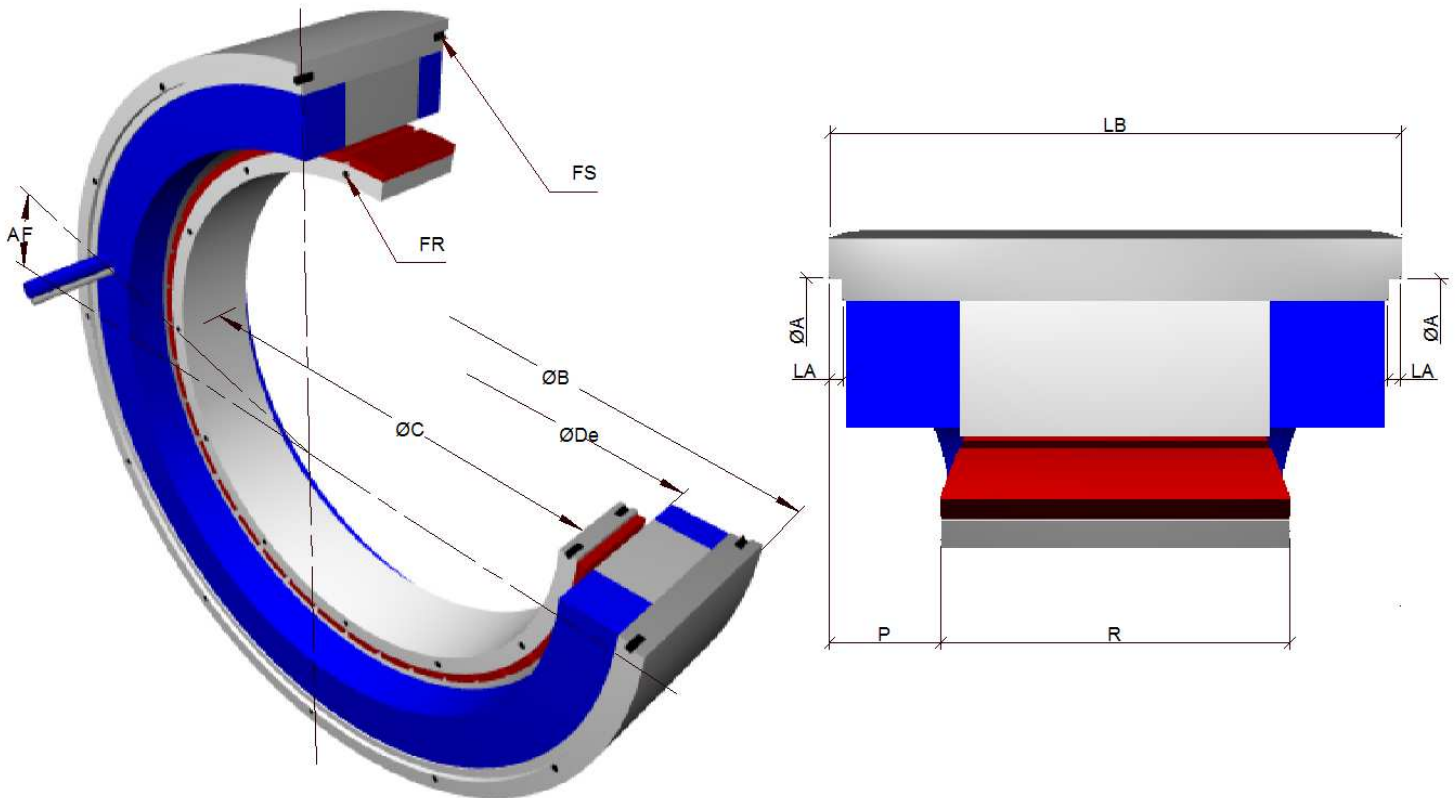

		400STK1M	400STK2M	400STK3M	400STK4M	400STK5M	400STK6M	400STK7M	400STK8M
Housing internal centering diameter	A H8	380	380	380	380	380	380	380	380
Angle wire output / tapped holes	AF	15°	15°	15°	15°	15°	15°	15°	15°
Housing external centering diameter	B Ø	404	404	404	404	404	404	404	404
Rotoric internal centering diameter	C H7	258	258	258	258	258	258	258	258
Housing internal diameter	De	306	306	306	306	306	306	306	306
Rotoric fixation holes	FR	12xM6 sur Ø268	12xM6 sur Ø268	12xM6 sur Ø268	12xM6 sur Ø268	12xM6 sur Ø268	12xM6 sur Ø268	12xM6 sur Ø268	12xM6 sur Ø268
Housing fixation holes	FS	12xM6 sur Ø390	12xM6 sur Ø390	12xM6 sur Ø390	12xM6 sur Ø390	12xM6 sur Ø390	12xM6 sur Ø390	12xM6 sur Ø390	12xM6 sur Ø390
Depth of housing internal centering diameter	LA	3	3	3	3	3	3	3	3
Housing length	LB ±0.15	100.5 (130.5)	128 (158)	155.5 (185.5)	183 (213)	210.5 (240.5)	238 (268)	265.5 (295.5)	293 (323)
Alignment rotor / housing	P ± 0.1	39 (69)	39 (69)	39 (69)	39 (69)	39 (69)	39 (69)	39 (69)	39 (69)
Maximum rotoric contact diameter	Pmax	287	287	287	287	287	287	287	287
Rotor length	R +0.15	27.5	55	82.5	110	137.5	165	192.5	220
Number of poles (number of pairs of poles)		24 (12)	24 (12)	24 (12)	24 (12)	24 (12)	24 (12)	24 (12)	24 (12)

## INTEGRATION :

- ✓ The cables are made of PU, class 6, foreseen for cable-bearing chains, 2 mt standard length, copper square section according rated current.
- ✓ Rotor / housing alignment (P) has to be executed within +/- 0.1 mm. Optionally, we can supply a mounting tool for achieving that alignment in case of assembly without possibility of accurate alignment.
- ✓ Thermal device cable consists of a shielded pair 2x2x0.25mm<sup>2</sup> section, 7mm external diameter.
- ✓ (De) represents:
  - 1- The maximum diameter passing inside the housing.
  - 2- The maximum diameter necessary for rotor assembly.
- ✓ (Pmax) diameter for pieces in contact with the rotor must never be exceeded.
- ✓ Tapped holes on each side of rotor and housing are angularly aligned.
- ✓ Cable positioning (AF) is theoretical. Leave a free room with a +/- 10 arc degrees tolerance around that position, on a 50 mm height from the housing side, for avoiding to force the cables at the alternator output.
- ✓ When designing the assembly, take care to insure a perfect contact between housing and user's bore for avoiding thermal problems.
- ✓ For housing mounting, use either external centering diameter (B) or internal centering diameters (A).
- ✓ For execution tolerances (perpendicularity, concentricity...), please consult us.
- ✓ In red in the table : P, LB, J4 and E3 are 30mm higher when the rated current is greater than 53 amps for class 6 shielded cable output.  
We also propose an output with unshielded wires that is not requiring an increase of length. (contact us for square section)

A full integration handbook can be supplied to our customers upon request  
For further information or specific request about our alternators, feel free to contact us.