

ALTERNATORS 800 STK

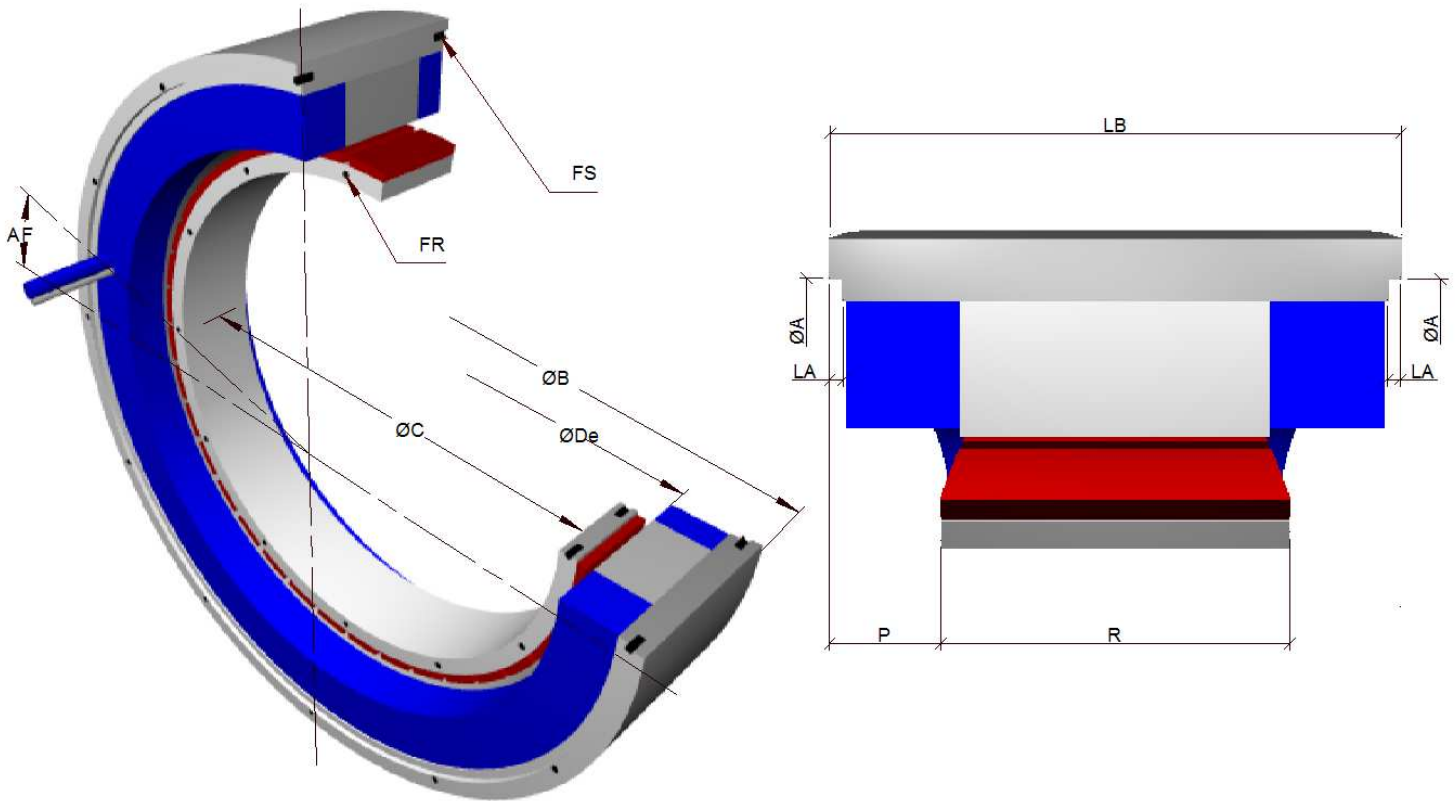

		800STK1M	800STK2M	800STK3M	800STK4M	800STK5M	800STK6M
Housing internal centering diameter	A H8	762	762	762	762	762	762
Angle wire output / tapped holes	AF	11.25	11.25	11.25	11.25	11.25	11.25
Housing external centering diameter	B Ø	795	795	795	795	795	795
Rotoric internal centering diameter	C H7	630	630	630	630	630	630
Housing internal diameter	De	689	689	689	689	689	689
Rotoric fixation holes	FR	16xM8 sur Ø645	16xM8 sur Ø645	16xM8 sur Ø645	16xM8 sur Ø645	16xM8 sur Ø645	16xM8 sur Ø645
Housing fixation holes	FS	16xM8 sur Ø774	16xM8 sur Ø774	16xM8 sur Ø774	16xM8 sur Ø774	16xM8 sur Ø774	16xM8 sur Ø774
Depth of housing internal centering diameter	LA	5	5	5	5	5	5
Housing length	LB ±0.15	112.5 (152.5)	140 (180)	167.5 (207.5)	195 (235)	222.5 (262.5)	250 (290)
Alignment rotor / housing	P ± 0.2	47 (87)	47 (87)	47 (87)	47 (87)	47 (87)	47 (87)
Maximum rotoric contact diameter	Pmax	666	666	666	666	666	666
Rotor length	R +0.15	27.5	55	82.5	110	137.5	165
Number of poles (number of pairs of poles)		48 (24)	48 (24)	48 (24)	48 (24)	48 (24)	48 (24)

INTEGRATION :

- ✓ The cables are made of PU, class 6, foreseen for cable-bearing chains, 2 mt standard length, copper square section according rated current.
- ✓ Rotor / housing alignment (P) has to be executed within +/- 0.2 mm. Optionally, we can supply a mounting tool for achieving that alignment in case of assembly without possibility of accurate alignment.
- ✓ Thermal device cable consists of a shielded pair 2x2x0.25mm² section, 7mm external diameter.
- ✓ (De) represents:
 - 1- The maximum diameter passing inside the housing.
 - 2- The maximum diameter necessary for rotor assembly.
- ✓ (Pmax) diameter for pieces in contact with the rotor must never be exceeded.
- ✓ Tapped holes on each side of rotor and housing are angularly aligned.
- ✓ Cable positioning (AF) is theoretical. Leave a free room with a +/- 10 arc degrees tolerance around that position, on a 50 mm height from the housing side, for avoiding to force the cables at the alternator output.
- ✓ When designing the assembly, take care to insure a perfect contact between housing and user's bore for avoiding thermal problems.
- ✓ For housing mounting, use either external centering diameter (B) or internal centering diameters (A).
- ✓ For execution tolerances (perpendicularity, concentricity...), please consult us.
- ✓ In red in the table : P, LB, J4 and E3 are 40mm higher when the nominal current is greater than 53 amps for class 6 shielded cable output.
We also propose an output with unshielded wires that is not requiring an increase of length. (contact us for square section)

A full integration handbook can be supplied to our customers upon request
For further information or specific request about our alternators, feel free to contact us.