

DIMENSIONS MOTEURS 300ST

Avec capteur de position 1 (fig. 1)

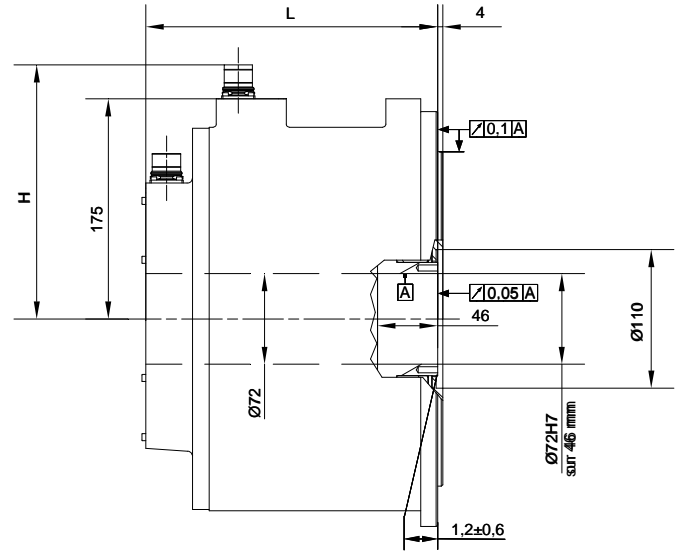
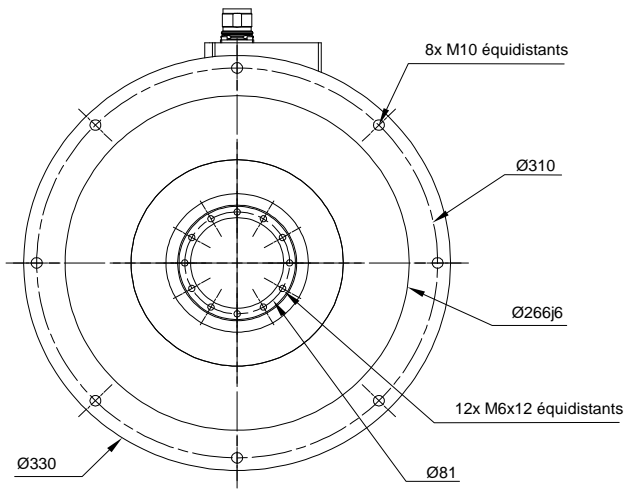

Avec capteur de position 2 ou 7 (fig. 2)

Détail des connecteurs

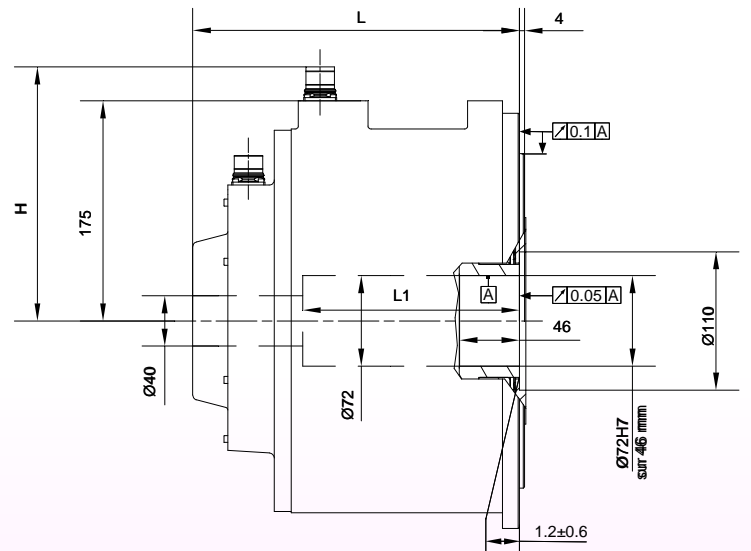
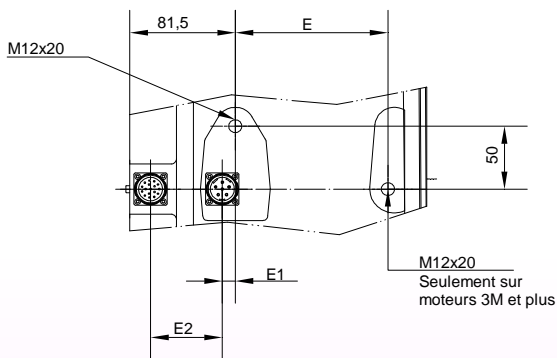

Avec capteur de position 3 (fig. 3)

Courant à couple permanent	H	E1	E2
< 25 A	202	10	55,5
> 25 A	217	2	63,5

MOTEUR	Capteur de position (page 10)				Tous
	1 (fig. 1)	2 ou 7 (fig. 2)	3 (fig. 3)		
Dimensions	L	L	L1	L	E
300ST1M	173.5	197.5	123	173.5	
300ST2M	201	225	150.5	201	
300ST3M	228.5	252.5	178	228.5	118
300ST4M	256	280	205.5	256	123
300ST5M	283.5	307.5	233	283.5	
300ST6M	311	335	260.5	311	

